

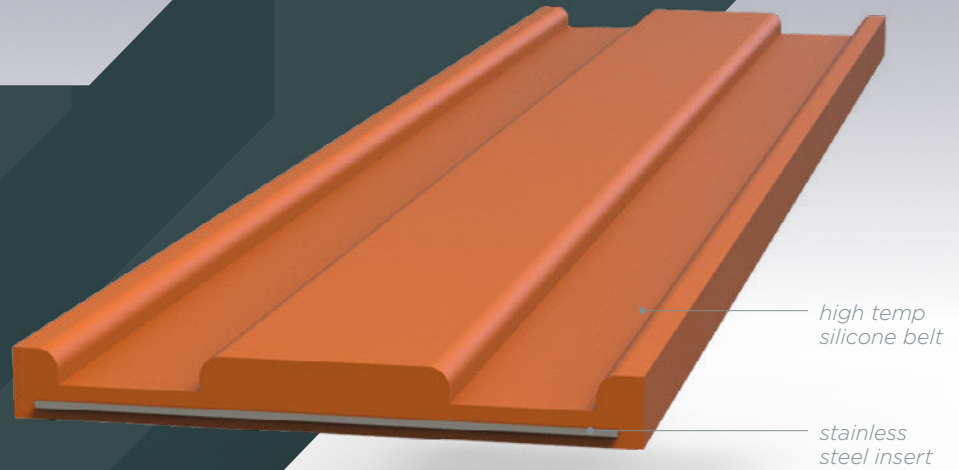

Flange Belt



high temp silicone belt

stainless steel insert

PRODUCT DESCRIPTION

Integrity Products Flange Belts provide a circumferential seal over the adjoining collars of flanges. This offers long term protection from external corrosive elements. The adjoining faces of flanges with gaskets generally form crevices which trap moisture, this allows the development of crevice corrosion and may lead to process leaks. Made from a high temperature rubber this flange belt is heat resistant up to 240°C (464°F), and suitable for flanges of all sizes.

PRODUCT APPLICATION

Integrity Products Flange Belt provides a cost-effective and long-lasting protection to the areas of flanges that are vulnerable to weathering and crevice corrosion. Integrity Products Flange Belt fully encompasses the outer diameter of the pipe flange and have an optional collection bottle for leak detection, providing an extra layer of personnel and environmental protection.

MATERIAL SPECIFICATIONS

MATERIAL(S)

belt:
60 Durometer Silicone
insert wire:
304 Stainless Steel Plate

COLOR

Orange

HARDNESS

55-60A

TENSILE STRENGTH

8 MPa

ELONGATION STRENGTH

300 %

TEMPERATURE RANGE

-76°F to 464°F (-60°C to 240°C)
Constant Temperature

INSTALLATION

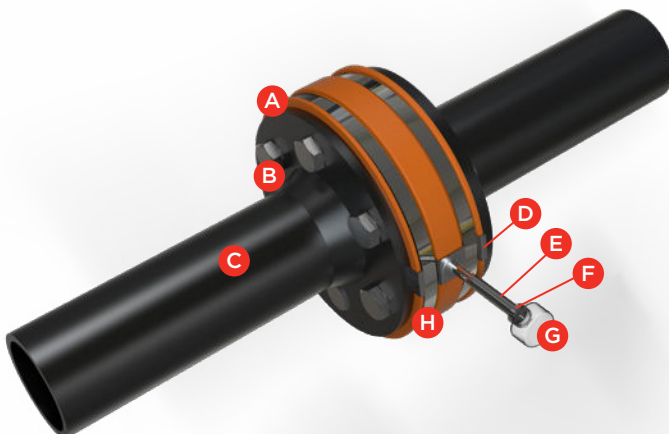

- A** HIGH TEMP SILICONE BELT
- B** FLANGE
- C** PIPE
- D** STAINLESS STEEL JOINER
- E** STAINLESS STEEL TUBE
- F** STAINLESS STEEL CAP
- G** COLLECTION BOTTLE
- H** STAINLESS STEEL BANDING