



PRODUCT DATASHEET
T-85
HEAT TRANSFER COMPOUND

APPLICATION

T-85 is a low to medium temperature heat transfer compound for use in moist and corrosive environments. Thermon's heat transfer compounds provide an efficient thermal bond between the tracer and the process equipment. By eliminating the air voids that would ordinarily exist, heat is directed into the surface being heated through conduction rather than convection and radiation. A single tracer utilizing Thermon's heat transfer compound has the equivalent performance of three to five convection (bare) tracers.

T-85 is typically utilized around valves and equipment where maximum exposure temperatures will not exceed 232°C (450°F). To reduce installation time and waste, this compound is available in 300 ml (10.1 oz) cartridges.

SPECIFICATIONS/RATINGS

Container sizes

T-85-C 300 ml (10.1 oz) cartridges

T-85-1 4 liters (1.06 gallons)

Maximum exposure temperature (ASTM E2550)

T-85 232°C (450°F)

Minimum exposure temperature -196°C (-320°F)

Minimum installation temperature

T-85 ambient temperature 0°C (32°F)

T-85 product temperature 10°C (50°F)

Heat transfer coefficient, U tracer to pipe wall

114-227 W/m² · °C (20-40 Btu/hr · °F · ft²)

Electrical resistivity 57 ohms-cm (146 ohms-inch)

Shelf life (unopened) 1 year

Bond Strength (ASTM D1002) > 13,800 kPa

(> 2000 lbs/in²)

Leachable Halogens (ASTM C871) < 200 ppm

Water-soluble no



DESCRIPTION

T-85 is available in 300 ml (10.1 oz) cartridges and 4 liter (1.06 gallon) pails.

BENEFITS

- Non soluble in water - no special curing required
- Epoxy resin base creates strong mechanical bond
- Suitable for moist or corrosive environments
- 300 ml (10.1 oz) cartridges allow easy application for valve and accessory heat tracing



PRODUCT DATASHEET
T-85
 HEAT TRANSFER COMPOUND

TYPICAL STEAM TRACING SYSTEM

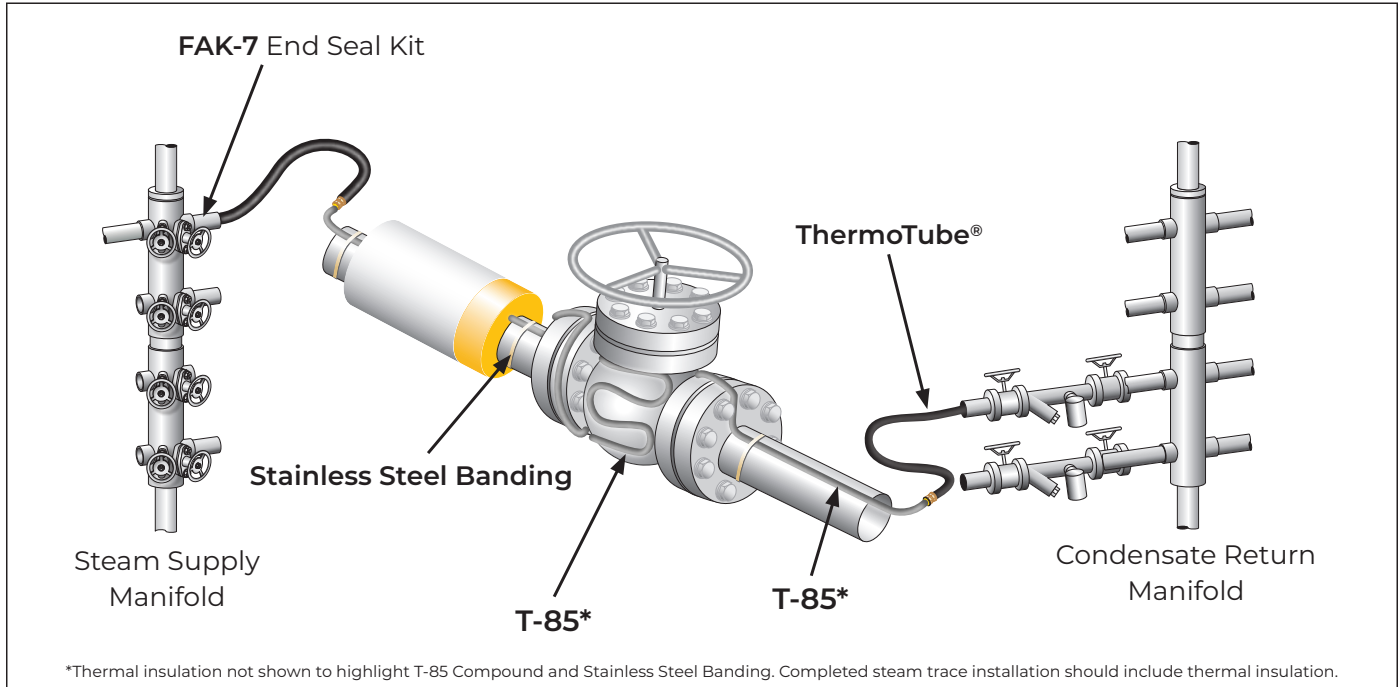

PRODUCT CONFIGURATIONS

Catalog Number	Description	Max. Exposure Temperature
T-85-C	300 ml (10.1 oz) Cartridges	232°C (450°F)
T-85-1	4 liter (1.06 gallon) Pail	232°C (450°F)

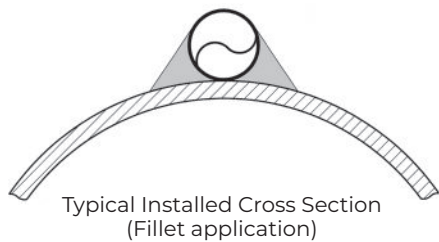

BASIC ACCESSORIES



MC-1 manual applicator.
AC-1 air-powered cartridge applicator with 50' of air hose.



Stainless Steel Banding...used to secure tracer to piping.

- **T2SSB** (.50" x .020") stainless banding for 3/8" and 1/2" O.D. tube tracers
- **T3SSB** (.50" x .030") stainless banding for 3/4" and 1" O.D. tube tracers and hard-pipe tracers

C001 banding tool for applying tension to T2SSB or T3SSB banding.

T34PB-CR crimp seals for fastening tensioned banding.

1950A crimping tool for T34PB-CR seals.



846-1E battery powered cartridge applicator for 300 ml (10.1 oz) cartridge T-85 Heat Transfer Compound. Battery pack and charger included.